

**Seating Position**

D

C

B

A

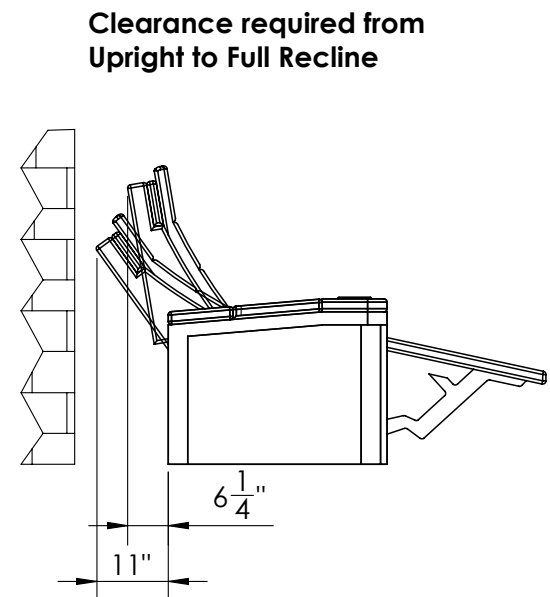
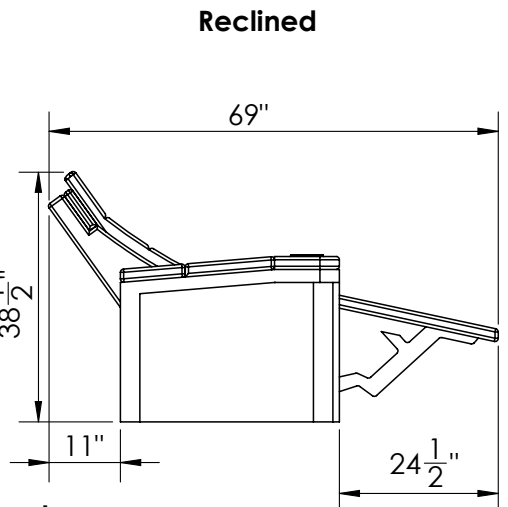
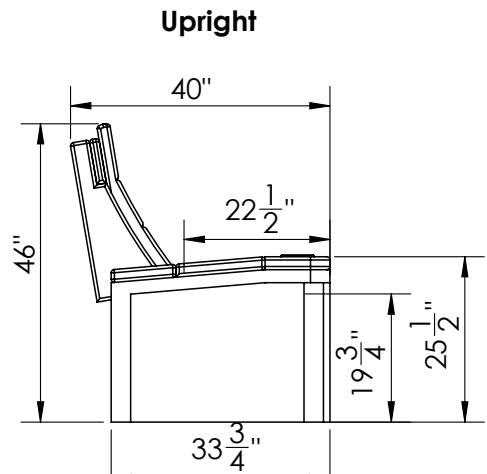

D

C

B

A

4

3

2

1

4

3

2

1

Lumbar Support

Headrest



**Monza Technical Specifications**

# Arm Configurations

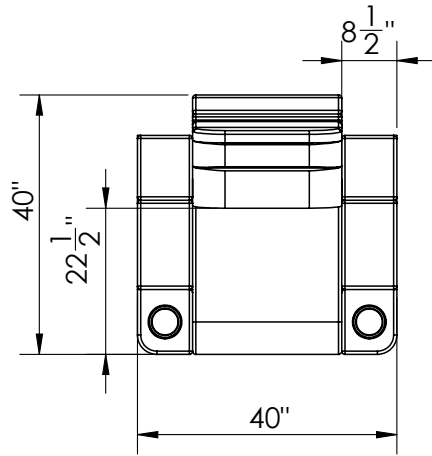

Double Arm

Single Left Arm

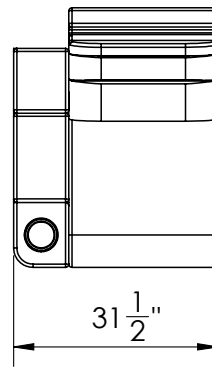

Single Right Arm

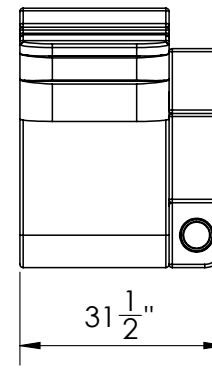

No Arm

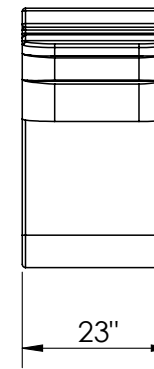

**Monza Technical Specifications**

**Sample Seating Configurations**

D

D

**Single**

40"

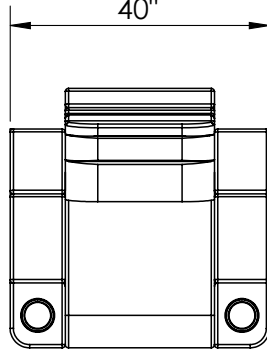

C

**Row of 2**

71 1/2"

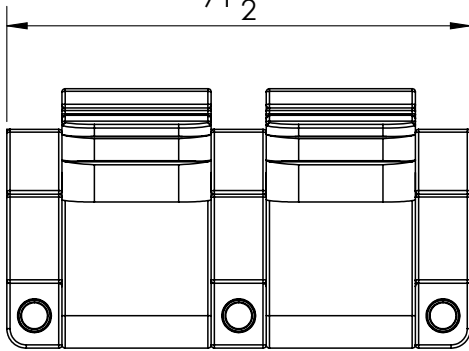

C

**Loveseat**

63"

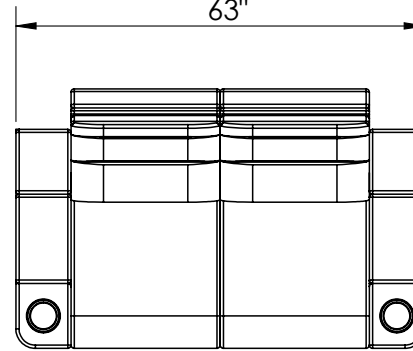

B

B

A

A

 *Valencia*  
HOME THEATER SEATING

**Monza Technical Specifications**

4

3

2

1

**Sample Seating Configurations**

**Row of 3**

103"

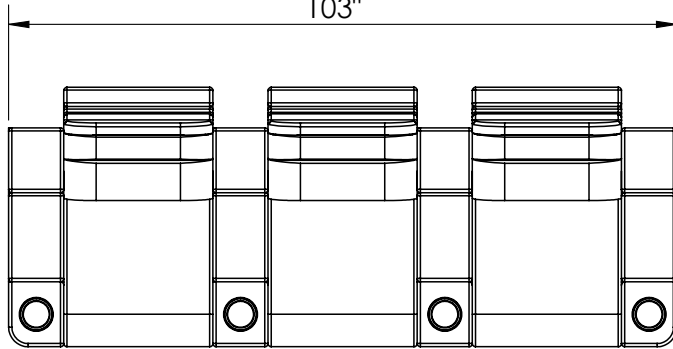

**Loveseat Left**

94 $\frac{1}{2}$ "

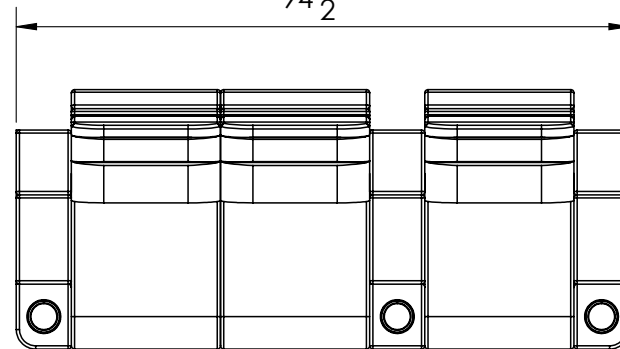

**Loveseat Right**

94 $\frac{1}{2}$ "

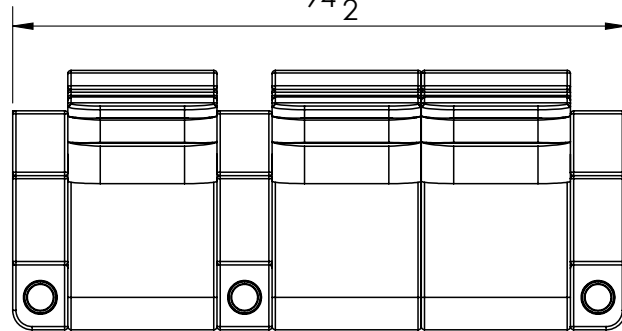

**Set of 3**

86"

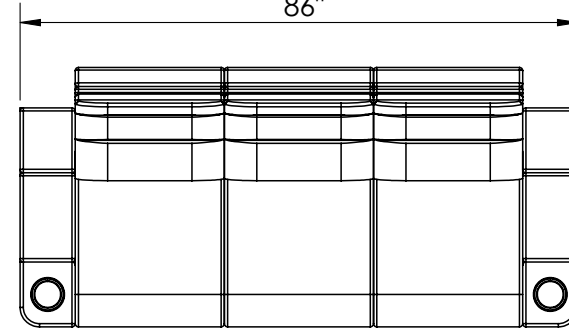

 *Valencia*  
HOME THEATER SEATING

**Monza Technical Specifications**

**Sample Seating Configurations**

D

C

B

A

D

C

B

A

4

3

2

1

4

3

2

1

**Row of 4**

134 $\frac{1}{2}$ "

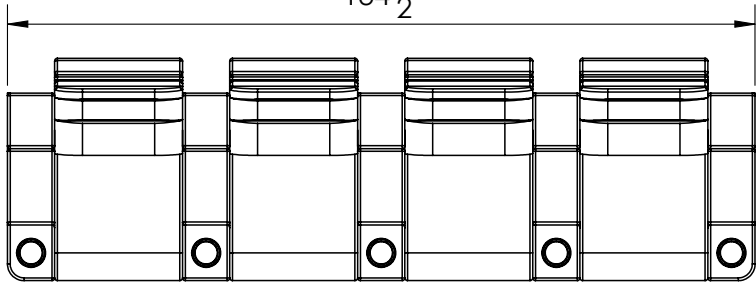

**Loveseat Double**

117 $\frac{1}{2}$ "

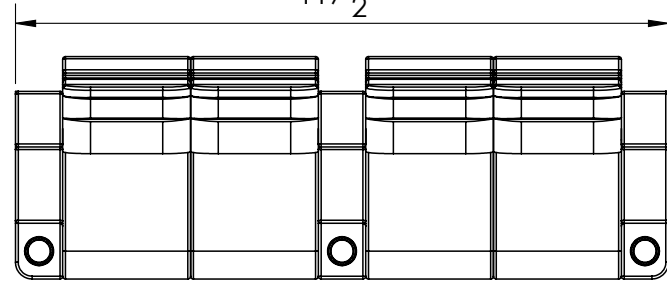

**Loveseat Centre**

126"

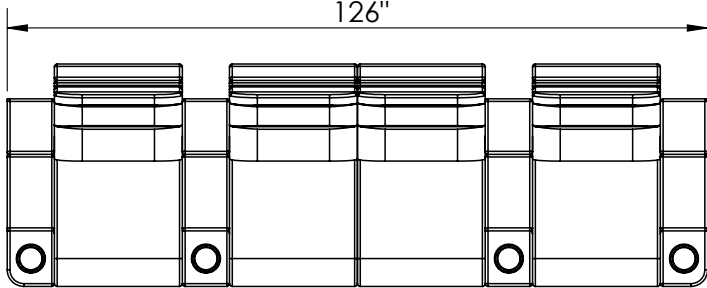

**Set of 4**

109"

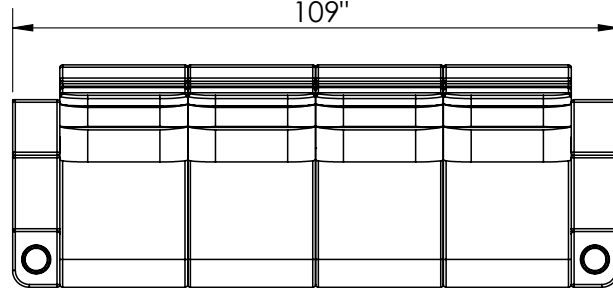

**Row of 5**

166"

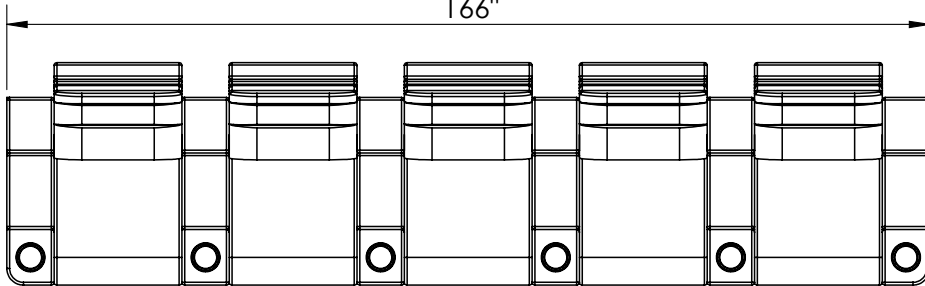

**Monza Technical Specifications**

### Sample Seating Configurations

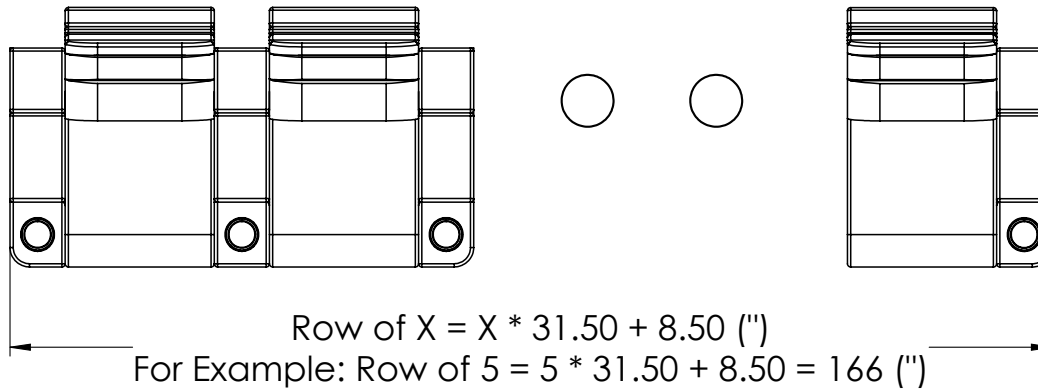

Row of X Seating Configurations: X = 1 Double + Y Left + Z Right

$X = 1 + Y + Z$

For example: Row of 6 = 1 Double + 0 Left + 5 Right

1 Double + 5 Left + 0 Right

1 Double + 2 Left + 3 Right

**Valencia**  
HOME THEATER SEATING

**Monza Technical Specifications**

**Sample Seating Configurations**

**Curved Row of 2**

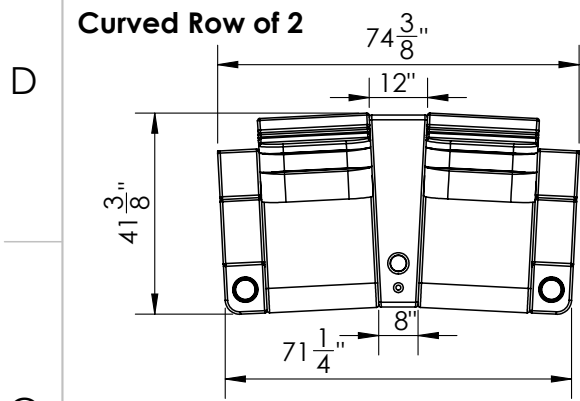

**Curved Row of 3**

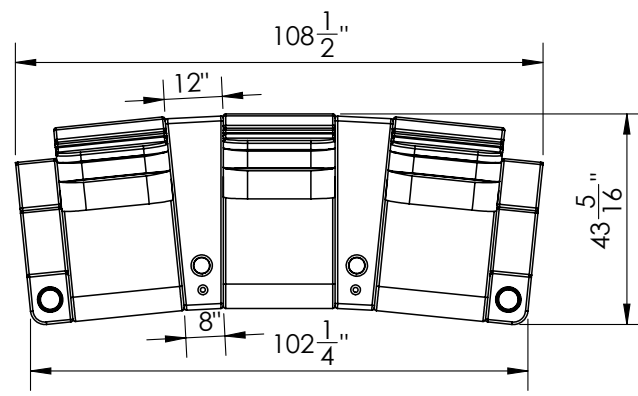

**Curved Row of 4**

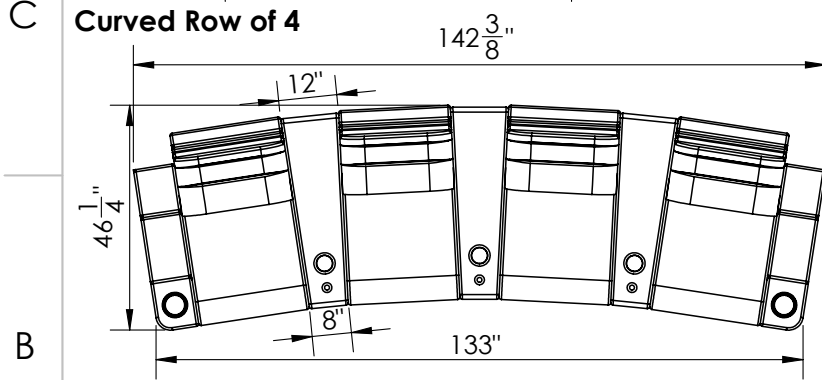

**Curved Loveseat Row of 4**

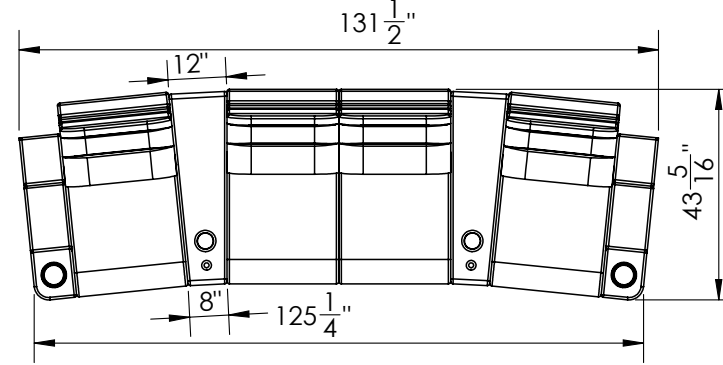

**Curved Row of 5**

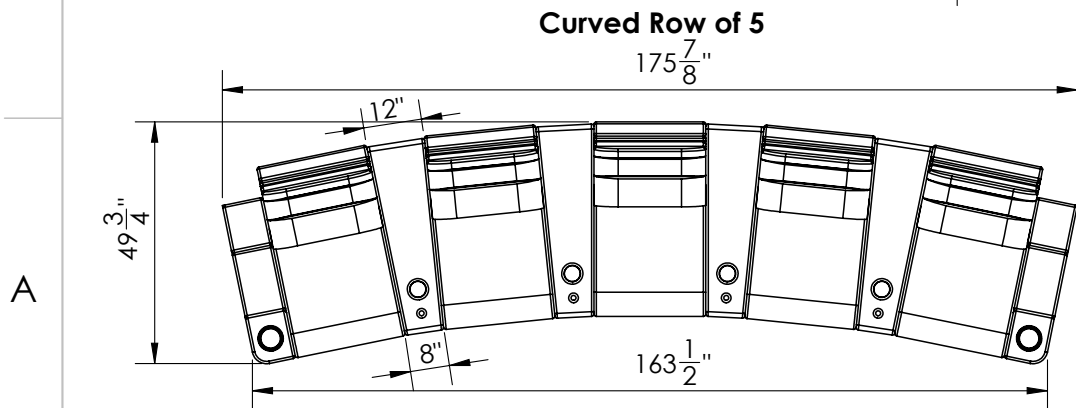

**Monza Technical Specifications**